

Digital Undercounter Compact Refrigerated Counter - 250lt, 1 Door, 2 Drawers no worktop (R290)

ITEM # _____

MODEL # _____

NAME # _____

SIS # _____

AIA # _____

725105 (SAL25N12)

 1-door and 2-drawer
 compact Refrigerated
 Counter 250lt, +2+10°C, AISI
 304, without worktop

Short Form Specification

Item No.

Constructed entirely in 304 AISI stainless steel. No worktop. High-density expanded polyurethane foam, 50 mm in thickness, with cyclopentane injection. Height-adjustable feet. Lower refrigerated compartment designed to accommodate GN 1/1 containers and equipped with N. 1 hinged door and N. 2 drawers. Built-in refrigeration unit. Ventilated. Refrigerant R290. Digital control panel. Automatic evaporation of defrost water. Drain outlet. Suitable to operate in ambient temperatures up to +43° C. Temperature range: +2+10°C. CFC and HCFC free.

Main Features

- Adjustable temperature range from 2 °C to 10 ° C to suit meat, fish and dairy storage requirements.
- Forced air circulation for rapid cooling and an even temperature distribution.
- Automatic evaporation of defrost water. Prearrangement for drain outlet.
- Connectivity ready for real time access to connected appliances from remote and data monitoring (requires optional accessory).
- Digital control panel.
- Anti-tilt runners accept GN 1/1 containers.
- A kit of wheels is available as optional accessory for easier movement.
- Tropicalized unit.

Construction

- IPX3 protected.
- Access to all components from the front.
- Built-in compressor to suit operating conditions.
- Constructed from AISI 304 Stainless steel throughout to meet the highest hygiene standards.
- Developed and produced in ISO 9001 and ISO 14001 certified factory.
- Mounted on legs with height adjustment.
- Rounded internal corners for ease of cleaning.
- Adjustable feet 66-88 mm (see optional accessory).

Sustainability



- CFC and HCFC free, highly ecological refrigerant type: R290 (ecological gas in foam: cyclopentane). Hydrocarbon refrigerant gas R290 for the lowest environmental impact (GWP=3), to reduce green house and ozone depletion effects.
- 50 mm insulation for energy saving.

Optional Accessories

- Kit 4 wheels for 250lt refrigerated counter, saladette PNC 880267
- Feet to reach 900mm height for 250lt saladette PNC 881254
- 1/1GN grey rilsan grid PNC 881435

APPROVAL: _____

Front

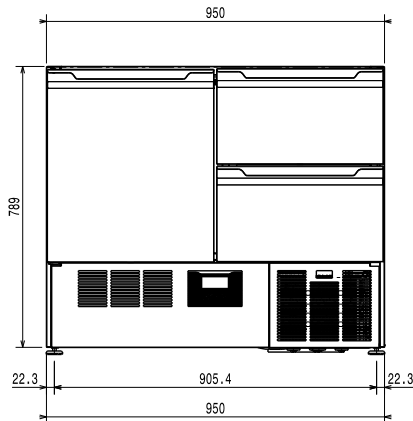

Side

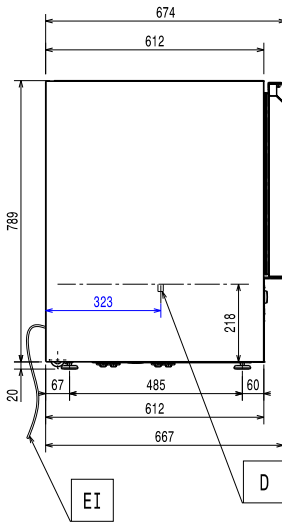

EI = Electrical inlet (power)

Top

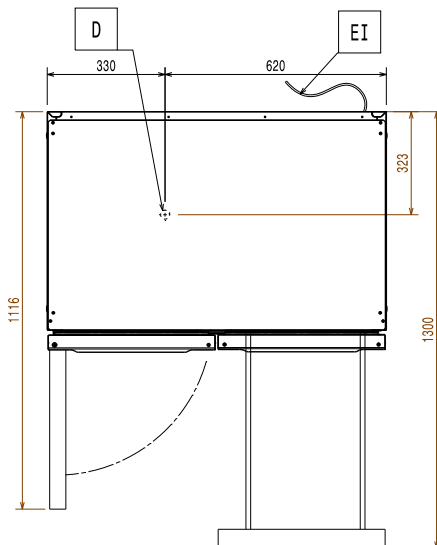

Electric

Supply voltage: 220-240 V/1 ph/50 Hz

Key Information:

Built-in Compressor and Refrigeration Unit

Net Volume: 117 lt

Door hinges:

External dimensions, Width: 950 mm

External dimensions, Depth: 674 mm

External dimensions, Height: 809 mm

Depth with doors open: 1116 mm

Gross capacity: 250 lt

Refrigeration Data

Compressor power: 1/4 hp

ISO Certificates

ISO Standards: ISO 9001; ISO 14001; ISO 45001; ISO 50001

Sustainability

Refrigerant type: R290

GWP Index: 3

Refrigeration power: 314 W

Refrigerant weight: 50 g

Energy Class (EU Reg. 2015/1094): D

Yearly and daily energy consumption (EU Reg. 2015/1094): 1100kWh/year - 3kWh/24h

Climate class (EU Reg. 2015/1094): Normal duty (cl.4)

Energy Efficiency Index-EEI (EU Reg. 2015/1094): 54.19

EU energy labelling from 1st July 2016

The European energy labelling scheme for professional refrigerators and freezers is based on requirements setting Minimum Energy Performance standards for commercial refrigeration cabinets sold within the EU.

These requirements are designed to drive energy efficiency and environmentally friendly approach for professionals. The European energy labelling scheme will apply to all manufacturers and importers who sell and market products within the EU and it is mandatory across Europe. Important: all products which consume energy above the minimum level will not be able to be sold within the EU from 1 July 2016.

SI 2020 No. 1528.

Important: all products which consume energy above the minimum level will not be able to be sold within the EU from 1 July 2016.

